

## Fiber Optic SFP FP 1310nm 1.25G Lightwave Transceiver with DDMI

Data Sheet

OFD2334-A

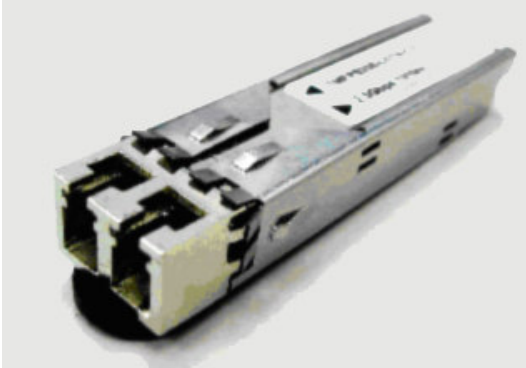

The OFD2334-A transceiver module operates at a wavelength of 1310 nm and at 1.25 Gb/s for Gigabit Ethernet 1000BASE-ELX and 1x Fiber Channel applications.

### Features

- Hot-pluggable
- Single +3.3 V supply
- Duplex LC connector interface
- Fabry-Perot 1310 type laser diode
- Output Optical Power: -6 to 0 dBm
- 20 km link distance
- Data Rate of 1.25 Gb/s, NRZ
- Internal Digital Diagnostics calibration
- Compliant with IEEE-802.3z Gigabit Ethernet 1000BASE-ELX at 1.25 Gb/s and Telcordia specifications for GR-468-CORE
- Multi-Source Agreement (MSA) for Small Form Factor Pluggable (SFP) Compliant
- Compatible with ANSI specifications for Fiber Channel applications at 1.06 Gb/s

### Applications

- Telecommunications and Data Communications system networks
- Gigabit Ethernet
- Fiber Channel links at 1.06 Gb/s
- Local and storage area networks
- High speed backplane interconnects
- Switched Backbones

### Description

The OFD2334-A transceiver provides signal conversion and processing for serial optical data communication applications. It operates over single mode fiber by converting 1310 nm wavelength lightwave information into an electrical signal and vice versa at a data rate of 1.25 Gb/s.

Housed in a compact metal package, the transceiver module consists of a transmitter and receiver optical subassembly coupled with a duplex LC receptacle.

This dual-fiber connector transceiver is designed for use in telecom and datacom networking system applications at 1.25 Gb/s for Gigabit Ethernet 1000BASE-ELX and 1x Fiber Channel applications.

**Transceiver Monitoring Interface**

OFD2334-A provides an enhanced monitoring interface, which allows real-time access to device operating parameters such as transceiver temperature, laser bias current, transmitted optical power, received optical power and transceiver supply voltage. It also defines a sophisticated system of alarm and warning flags, which alerts end-users when particular operating parameters are outside of a normal factory-set range. The monitoring interface makes use of two wire address 1010001X (A2h) and is backward compatible with the Small Form Pluggable Multi-Source Agreement (SFP MSA).

**Serial Identification (EEPROM)**

An SFP having module definition 4 provides access to sophisticated identification information that describes the SFP transceiver’s capabilities, standard interface, manufacturer and other information. An EEPROM containing the detailed product information and digital diagnostic function for the host equipment is accessed by the 2-wire serial CMOS EEPROM protocol. See SFP MSA for detailed description.

**Performance Specifications**

**Absolute Maximum Ratings**

Stresses in excess of the absolute maximum ratings can cause damage to the optical device. Operations of the optical device are suggested to remain within the recommended operating conditions. Exposure to the absolute maximum ratings for extended periods can adversely affect device reliability.

Parameter	Symbol	Minimum	Maximum	Unit
Storage Temperature	T <sub>S</sub>	-40	+85	°C
Lead Soldering Temperature	T <sub>SOLD</sub>	-	+260	°C
Operating Temperature	T <sub>A</sub>	-40	+85	°C
Supply Voltage	V <sub>CC</sub>	0	6	V

**Transmitter Electrical Interface (-40°C to +85°C)**

Parameter	Symbol	Minimum	Maximum	Unit
Supply Current	I <sub>CC_T</sub>	-	200	mA
Input LOW Voltage (Tx Disable)	V <sub>IL</sub>	0	0.8	V
Input HIGH Voltage (Tx Disable)	V <sub>IH</sub>	2.0	V <sub>CC</sub>	V
Output LOW Voltage (Tx Fault)	V <sub>OL</sub>	0	0.8	V
Output HIGH Voltage (Tx Fault)	V <sub>OH</sub>	2.0	V <sub>CC</sub>	V

**Safety**

**Laser Compliance Statement**

The OFD2334-A is classified as a Class I Laser Product. It complies with IEC 60825-1 and FDA 21 CFR 1040.10 and 1040.11. The transceiver must be operated under recommended operating conditions; otherwise classification for laser product safety is invalid. Because the transceiver is designed to be inherently eye safe, it does not require open fiber control thus eliminating complex electronics or mechanics.

Caution - use of device other than those specified herein may result in hazardous laser radiation exposure or other damage. Please embrace all customary precautions and discretion while handling this device.

**Receiver Electrical Interface (-40°C to +85°C)**

Parameter	Symbol	Minimum	Maximum	Unit
Supply Current	I <sub>CCR</sub>	-	100	mA
Data Output (Diff Volt)	V <sub>OD</sub>	0.4	1.3	V
Output LOW Voltage (Rx LOS)	V <sub>OL</sub>	0	0.8	V
Output HIGH Voltage (Rx LOS)	V <sub>OH</sub>	2.0	V <sub>CC</sub>	V
LOW MOD_DEF(1), MOD_DEF(2)	V <sub>IL</sub>	-0.6	V <sub>CC</sub> x 0.3	V
HIGH MOD_DEF(1), MOD_DEF(2)	V <sub>IH</sub>	V <sub>CC</sub> x 0.7	V <sub>CC</sub> + 0.5	V

**Transmitter Electro-Optical Specifications**

Parameter	Symbol	Minimum	Typical	Maximum	Unit
Supply Voltage	V <sub>CCT</sub>	3.1	3.3	3.5	V
Supply Current	I <sub>CCT</sub>			200	mA
Optical Center Wavelength	λ		1310		nm
Output Optical Power <sup>1</sup> (average)	P <sub>OUT</sub>	-6		0	dBm
Extinction Ratio	E <sub>r</sub>	10			dB
Rise Time (20% - 80%)	T <sub>r</sub>			260	ps
Fall Time (20% - 80%)	T <sub>f</sub>			260	ps

**Note:**

- Optical output for distances of 20 kilometers.

**Receiver Electro-Optical Specifications**

Parameter	Symbol	Minimum	Typical	Maximum	Unit
Supply Voltage	V <sub>CCT</sub>	3.1	3.3	3.5	V
Supply Current	I <sub>CCT</sub>			100	mA
Optical Center Wavelength	λ		1310		nm
Data Output Differential Voltage	V <sub>D</sub>		0.6		V
Optical Input Sensitivity (average)	P <sub>IN</sub>			-21	dBm
Signal Detect-Assert	P <sub>A</sub>			-22	dBm
Signal Detect-Deassert	P <sub>D</sub>	-40			dBm
Signal Detect-Hysteresis	P <sub>A</sub> - P <sub>D</sub>	0.5			dB

**Monitoring Specifications**

Parameter	Range	Accuracy	Calibration
Temperature	0 to 70°C	±3°C	Internal
Voltage	3.0 to 3.6 V	±3%	Internal
Bias Current	0 to 100 mA	±10%	Internal
Tx Power	-15 to 0dBm	±3dBm	Internal
Rx Power	-25 to -5 dBm	±3dBm	Internal

Pin Assignment

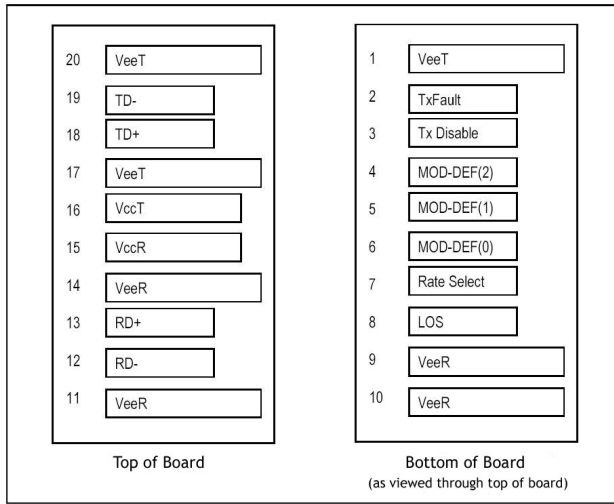

Pin Description and Plug-in Sequence<sup>1</sup> (1-Grd, 2-Power, 3-Signal)

Pin No.	Name	Description	Plug-in Sequence	Notes
1	VeeT	Transmitter Ground	1	
2	TX Fault	Transmitter Fault Indication	3	
3	TX Disable	Transmitter Disable	3	Module disables on high or open.
4	MOD-DEF 2	Module Definition 2	3	2 wire serial ID interface
5	MOD-DEF 1	Module Definition 1	3	2 wire serial ID interface
6	MOD-DEF 0	Module Definition 0	3	Grounded in module
7	Rate Select	Bandwidth Selection	3	Low or open - reduced bandwidth, High - full bandwidth
8	LOS	Loss of Signal	3	
9	VeeR	Receiver Ground	1	
10	VeeR	Receiver Ground	1	
11	VeeR	Receiver Ground	1	
12	RD-	Inv. Received Data Out	3	
13	RD+	Received Data Out	3	
14	VeeR	Receiver Ground	1	
15	VccR	Receiver Power	2	3.3 ± 5%
16	VccT	Transmitter Power	2	3.3 ± 5%
17	VeeT	Transmitter Ground	1	
18	TD+	Transmit Data In	3	
19	TD-	Inv. Transmit Data In	3	
20	VeeT	Transmitter Ground	1	

Note:

1. Pin engagement sequence during hot plugging.

**Physical Characteristics**

**Outline Diagram**

Dimensions for the device package are also given in its corresponding Dimensions table.

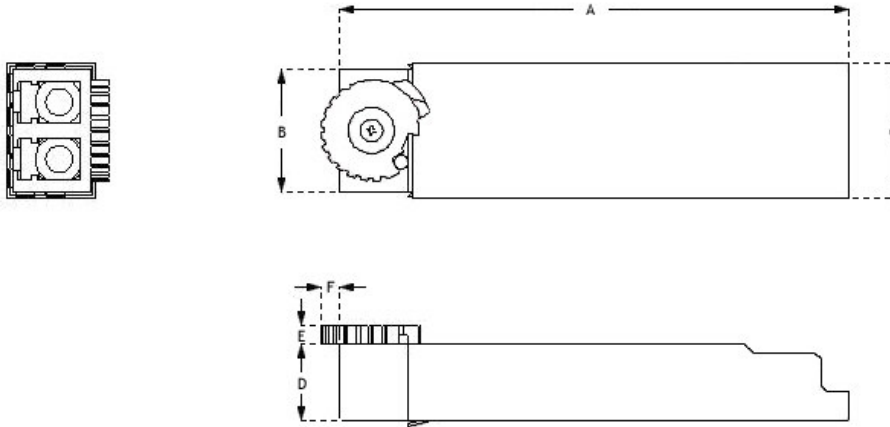

**Dimensions Table**

Dimensions	Inches	Metric (mm)
A	2.185	55.50±0.1
B	0.528	13.40
C	0.575	14.60
D	0.335	8.50±0.1
E	0.075	1.90
F	0.08	2.00

**Additional Information**

**Contact**

For additional information, product specifications, or information about Optocom:

Internet: <http://www.optocom.com>

Email: [sales@optocom.com](mailto:sales@optocom.com)

Tel: +1 978 988 8711

Fax: +1 978 988 8722

©2005 Optocom Corporation. All rights reserved. Information in this document is believed to be accurate and reliable and is subject to change without notice. Optocom Corporation will not be held liable for technical or editorial errors or omissions contained herein. Reproduction in whole or in part is prohibited without prior written consent of the copyright owner and no responsibility will be assumed by Optocom Corporation for any infringements of third parties. All other brand or product names mentioned are the trademarks or registered trademarks owned by their respective companies or organizations.