

Fiber Optic SFP DFB 1550nm 1.25G Transceiver with APD Photodiode and DDMI

Data Sheet

OFD3379



The OFD3379 transceiver module operates at a wavelength of 1550 nm and at 1.25 Gb/s for Gigabit Ethernet 1000BASE-EZX and 1x Fiber Channel applications.

Features

- Hot-pluggable
- Single +3.3 V supply
- Duplex LC connector interface
- Distributed Feedback 1550 type LD
- Low power dissipation
- IEEE 802.3z Gigabit Ethernet 1000BASE-EZX compliant
- Fiber Channel compliant
- APD receiver
- Power Output: 0 to +5 dBm
- 110 km link distance
- Internal Digital Diagnostics calibration
- Digital Diagnostics Monitoring for SFF-8472 compatible
- Multi-Source Agreement (MSA) for Small Form Factor Pluggable (SFP) Compliant

Applications

- Telecommunications and Data Communications system networks
- Gigabit Ethernet
- Point-to-Point networking
- Metro Access Rings
- 1x Fiber Channel

Description

The OFD3379 transceiver provides signal conversion and processing for serial optical data communication applications. It operates over single mode fiber by converting 1550 nm wavelength lightwave information into an electrical signal and vice versa at a data rate of 1.25 Gb/s.

Housed in a compact metal package, the transceiver module consists of a transmitter and receiver optical subassembly coupled with a duplex LC receptacle. A high-speed uncooled DFB laser diode operates as light source while an APD photodiode subsequently acts as a detector.

This dual-fiber connector transceiver is designed for use in Gigabit Ethernet 1000BASE-EZX and 1x Fiber Channel applications.

Transceiver Monitoring Interface

OFD3379 provides an enhanced monitoring interface, which allows real-time access to device operating parameters such as transceiver temperature, laser bias current, transmitted optical power, received optical power and transceiver supply voltage. It also defines a sophisticated system of alarm and warning flags, which alerts end-users when particular operating parameters are outside of a normal factory-set range. The monitoring interface makes use of two wire address 1010001X (A2h) and is backward compatible with the Small Form Pluggable Multi-Source Agreement (SFP MSA).

Serial Identification (EEPROM)

An SFP having module definition 4 provides access to sophisticated identification information that describes the SFP transceiver’s capabilities, standard interface, manufacturer and other information. An EEPROM containing the detailed product information and digital diagnostic function for the host equipment is accessed by the 2-wire serial CMOS EEPROM protocol. See SFP MSA for detailed description.

Performance Specifications

Absolute Maximum Ratings

Stresses in excess of the absolute maximum ratings can cause damage to the optical device. Operations of the optical device are suggested to remain within the recommended operating conditions. Exposure to the absolute maximum ratings for extended periods can adversely affect device reliability.

Parameter	Symbol	Minimum	Maximum	Unit
Storage Temperature	T _S	-40	+85	°C
Supply Voltage	V _{CC}	0	4.0	V
Relative Humidity	RH	5	85	%

Recommended Operating Conditions

Parameter	Symbol	Minimum	Typical	Maximum	Unit
Operating Temperature	T _{OP}	0		70	°C
Supply Voltage	V _{CC}	3.1	3.3	3.5	V
Supply Current	I _{TX} + I _{RX}		200	300	mA

Safety

Laser Compliance Statement

The OFD3379 is classified as a Class I Laser Product and complies with IEC 60825-1 and FDA 21 CFR 1040.10 and 1040.11. The transceiver must be operated under recommended operating conditions. Because the transceiver is designed to be inherently eye safe, it does not require open fiber control thus eliminating complex electronics or mechanics.

Caution - use of device other than those specified herein may result in hazardous laser radiation exposure or other damage. Please embrace all customary precautions and discretion while handling this device.

Transmitter Electro-Optical Interface (T_C = 0~70°C; V_{CC}T,R = 3.1V < V_{CC} < 3.5V)

Parameter	Symbol	Minimum	Maximum	Unit
Transmitter Differential Input Voltage	TD +/-	400	2000	mVp-p
Optical Output Power ¹	P _O	0	+5	dBm
Optical Extinction Ratio ¹	E _R	9		dB
Center Wavelength ¹	λ _C	1530	1570	nm
Spectral Width ¹	Δλ		< 1	nm
Side Mode Suppression Ratio ¹	SMSR	30		dB
Optical Rise/ Fall Time ²	t _r / t _f		0.25	nsec
Tx_Fault - HIGH	V _{Fault_H}	2	V _{CC}	V
Tx_Fault - LOW	V _{Fault_L}	V _{ee}	V _{ee} + 0.5	V
Tx_Disable - High	V _{Disable_H}	2	V _{CC}	V
Tx_Disable - LOW	V _{Disable_L}	V _{ee}	V _{ee} + 0.8	V

Note:

1. Measured at 1250 Mbps, PRBS 2⁷-1, NRZ.
2. 20%-80%

Receiver Electro-Optical Specifications (T_C = 0~70°C; V_{CC}T,R = 3.1V < V_{CC} < 3.5V)

Parameter	Symbol	Minimum	Typical	Maximum	Unit
Receiver Differential Output Voltage	RD +/-	600	800		mVp-p
Receiver Overload ^{1,2}	P _{IN} MAX	-8			dBm
Receiver Sensitivity ^{1,2}	P _{IN} MAX			-30	dBm
Operating Center Wavelength	λ _C	1270		1620	nm
Receiver LOS Assert Level ²	P _{RX_LOS A}	-45			dBm
Receiver LOS Deassert Level ²	P _{RX_LOS D}			-30.5	dBm
Receiver Loss of Signal Hysteresis ²		0.5	2		dB

Note:

1. With BER better than or equal to 1x10⁻¹².
2. Measured in center of eye opening with 2⁷-1 PRBS, NRZ.

Pin Assignment

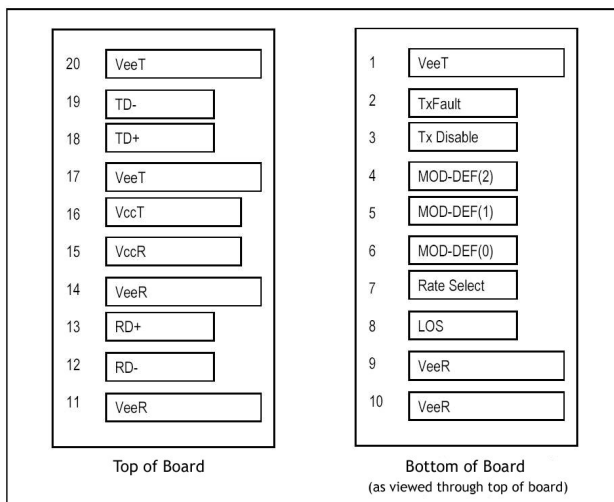

Figure 1. SFP Transceiver Electric Pad Layout

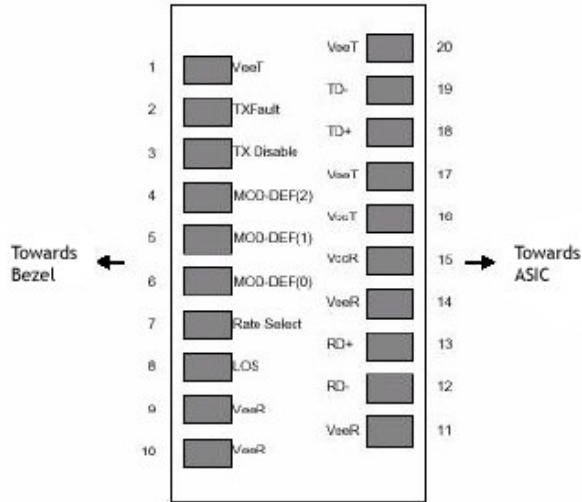

Figure 2. Diagram of Host Board Connector Block Pin

Pin Description and Plug-in Sequence¹ (1-Grd, 2-Power, 3-Signal)

Pin No.	Name	Description	Plug-in Sequence	Notes
1	VeeT	Transmitter Ground	1	Circuit ground is internally isolated from chassis ground.
2	TX Fault	Transmitter Fault Indication	3	Open-Collector outputs, asserted when LD and/or APC function fail.
3	TX Disable	Transmitter Disable	3	Disable when high voltage (>2.0V or Open).
4	MOD-DEF 2	Module Definition 2	3	Should be pulled up with 4.7k - 10 kΩ on host board to voltage between 2.0V and 5.5V. MOD-DEF (0) pulls line low to indicate module is plugged in.
5	MOD-DEF 1	Module Definition 1	3	See notes for Pin 4.
6	MOD-DEF 0	Module Definition 0	3	See notes for Pin 4.
7	Rate Select	Bandwidth Selection	3	No connection required.
8	LOS	Loss of Signal	3	LOS is Open-Collector output. Should be pulled up with 4.7k - 10kΩ on host board to a voltage between 2.0V and 5.5V. Logic 0 indicates normal operation; logic 1 indicates loss of signal.
9	VeeR	Receiver Ground	1	See notes for Pin 1.
10	VeeR	Receiver Ground	1	See notes for Pin 1.
11	VeeR	Receiver Ground	1	See notes for Pin 1.
12	RD-	Inv. Received Data Out	3	
13	RD+	Received Data Out	3	
14	VeeR	Receiver Ground	1	See notes for Pin 1.
15	VccR	Receiver Power	2	
16	VccT	Transmitter Power	2	

OFD3379 SFP TRANSCEIVER DATA SHEET

17	VeeT	Transmitter Ground	1	See notes for Pin 1.
18	TD+	Transmit Data In	3	
19	TD-	Inv. Transmit Data In	3	
20	VeeT	Transmitter Ground	1	See notes for Pin 1.

Note:

1. Pin engagement sequence during hot plugging.

Physical Characteristics

Outline Diagram

Dimensions for the device package are given in millimeters.

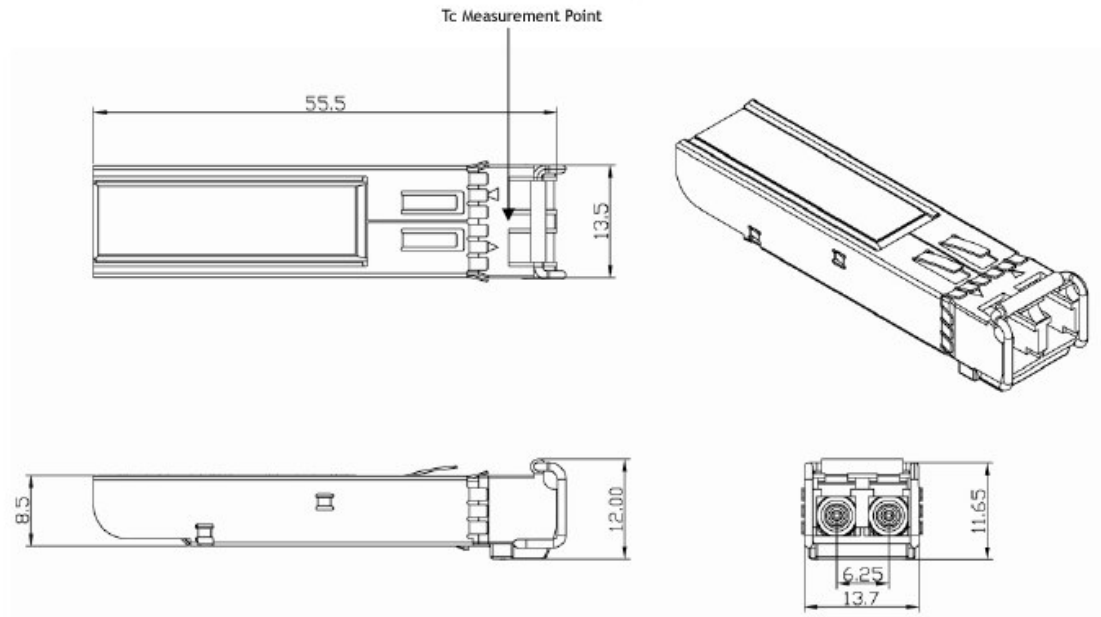

References (from SFP MSA)

SFP Host PCB Layout

- Notes:
1. Datum and basic dimensions established by customer.
 2. Pads and vias are chassis ground, 11 places.
 3. Thru holes, plating optional.

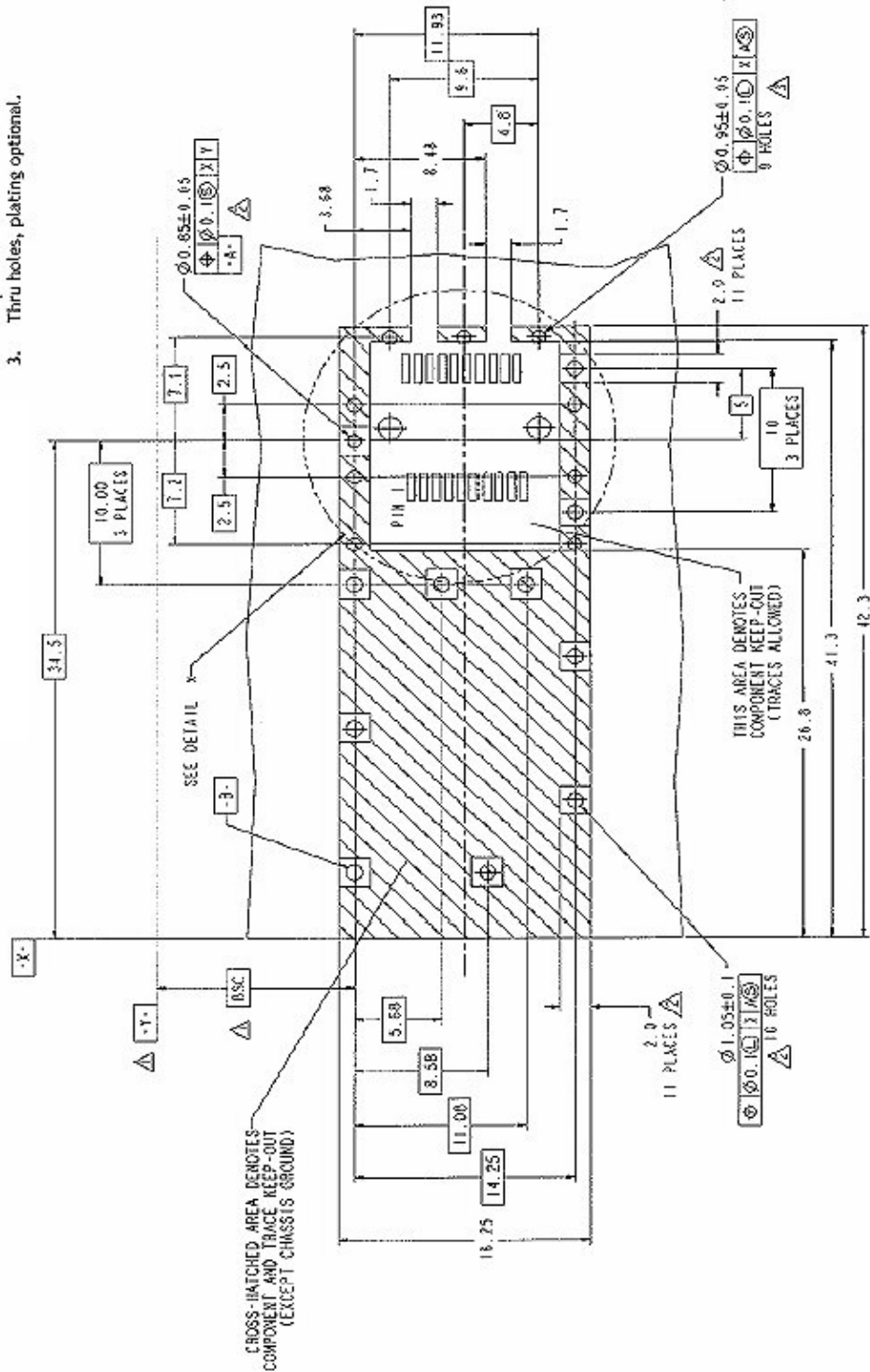

Recommended Interface Diagram

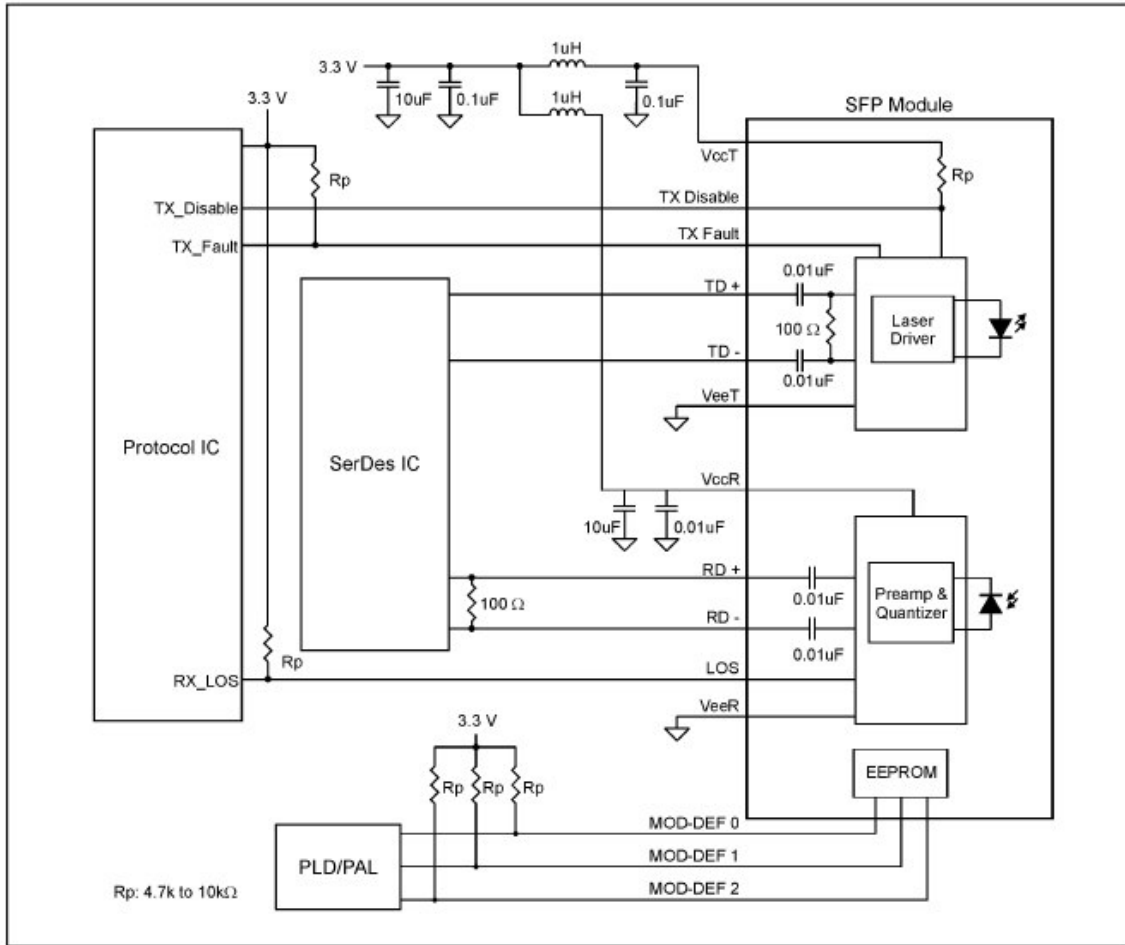

Additional Information

Contact

For additional information, product specifications, or information about Optocom:

Internet: <http://www.optocom.com>

Email: sales@optocom.com

Tel: +1 978 988 8711

Fax: +1 978 988 8722

©2005 Optocom Corporation. All rights reserved. Information in this document is believed to be accurate and reliable and is subject to change without notice. Optocom Corporation will not be held liable for technical or editorial errors or omissions contained herein. Reproduction in whole or in part is prohibited without prior written consent of the copyright owner and no responsibility will be assumed by Optocom Corporation for any infringements of third parties. All other brand or product names mentioned are the trademarks or registered trademarks owned by their respective companies or organizations.