

Fiber Optic 1x9 Transceiver For 1310 FP 155 Mb/s with SC Connector

Data Sheet

OFN2136



Features

- 1310 nm Fabry-Perot (FP) laser diode
- Data Rate: 155 Mbps, NRZ
- Single +3.3V Power Supply
- Plastic housing
- Duplex SC Connector
- Industry Standard 1x9 Output Footprint
- Supplies Differential PECL
- Compliance with IEEE802.3z
- Compliance with ITU-T G.957 STM-1 L-1.1

Applications

- FDDI
- ATM (Asynchronous Transfer Mode)
- ITU-T G.957 STM-1 L-1.1

Description

The OFN2136 is a high performance industry standard 1x9 transceiver module that combines a 1310 nm Fabry-Perot (FP) laser diode and PIN receiver for fiber cable 9/125 μm SMF. It supplies the Differential PECL with a single +3.3V power supply at a data rate of 155 Mb/s over single mode fiber for a link distance of 40 km.

Housed in a compact plastic package, the transceiver module consists of a transmitter and receiver optical subassembly coupled with duplex SC receptacle. The transceiver module operates at a nominal wavelength of 1310 nm for long reach applications.

Functional Diagram

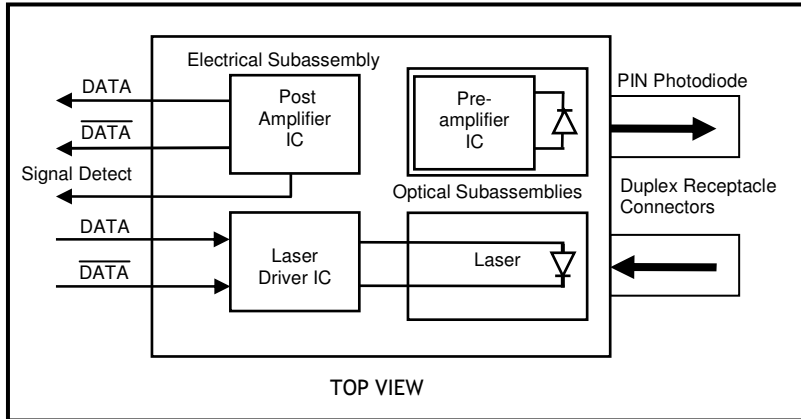

Data Input: PECL compatible differential data input to laser diode
 Signal Output: PECL compatible differential output of limiting amplifier
 Alarm Function: Signal Detect (SD)

Safety

Laser Compliance Statement

The OFN2136 is classified as a Class I Laser Product and complies with IEC 60825-1 and FDA 21 CFR 1040.10 and 1040.11. The transceiver must be operated under recommended operating conditions. Because the transceiver is designed to be inherently eye safe, it does not require open fiber control thus eliminating complex electronics or mechanics.

Caution - use of device other than those specified herein may result in hazardous laser radiation exposure or other damage. Please embrace all customary precautions and discretion while handling this device.

Performance Specifications

Absolute Maximum Ratings

Stresses in excess of the absolute maximum ratings can cause damage to the optical device. Operations of the optical device are suggested to remain within the recommended operating conditions. Exposure to the absolute maximum ratings for extended periods can adversely affect device reliability.

Parameter	Symbol	Minimum	Typical	Maximum	Unit
Storage Temperature	T _s	-40		85	°C
Lead Soldering Temperature	S _{temp}			260	°C
Lead Soldering Time	S _{time}			10	Sec
Supply Voltage	V _{cc}	3.1	3.3	3.5	V
Operating Temperature	T _A	0		70	°C

Transmitter Electro-Optical Characteristics

Parameter	Symbol	Minimum	Typical	Maximum	Unit
Output Optical Power ¹	P _o	-5		0	dBm
Optical Extinction Ratio ¹	E _r	10			dB
Optical Rise Time (20% - 80%) ²	T _r			1.3	nsec
Optical Fall Time (20% - 80%) ²	T _f			1.3	nsec
Center Wavelength	λ	1270	1310	1360	nm
Spectral Width (RMS)	Δλ		2	3	nm
Supply Voltage	V _{ccT}	3.1	3.3	3.5	V
Supply Current	I _s			150	mA
Input Voltage (HIGH) ³	V _{IH}	V _{ccT} -1.17		V _{ccT} -0.73	V
Input Voltage (LOW) ³	V _{IL}	V _{ccT} -1.95		V _{ccT} -1.45	V

Notes:

1. Measured at the end of 100m length 9/125 μm step index fiber cable using 155 Mbps, PRBS 2²³-1. Signal at the beginning of life.
2. Measured using 125 Mbps 1010 signal.
3. V_{ccT} = 3.3 V, T_c=25 °C.

Receiver Electro-Optical Characteristics

Parameter	Symbol	Minimum	Typical	Maximum	Unit
Optical Input Wavelength	λ	1260		1580	nm
Saturation Power ¹	P _{sat}			-10	dBm
Sensitivity ¹	P _{in}	-36			dBm
SD Assert Level ²	P _a			-36.5	dBm
SD Deassert Level ²	P _d	-45			dBm
SD Hysteresis ²	Phys	0.5	2	5	dB
Supply Voltage	V _{ccR}	3.1	3.3	3.5	V
Supply Current ³	I _s			150	mA
Output Voltage (HIGH) ^{4,5}	V _{OH}	V _{ccR} -1.03		V _{ccR} -0.88	V
Output Voltage (LOW) ^{4,5}	V _{OL}	V _{ccR} -1.81		V _{ccR} -1.62	V
Rise Time Output Signal ⁶	T _{ROUT}		1	2	nsec
Fall Time Output Signal ⁶	T _{FOUT}		1	2	nsec

Notes:

1. BER=1 × 10⁻¹⁰, 155 Mbps, PRBS 2²³-1.
2. 125 Mbps, 1010 signal.
3. Output currents are not included.
4. Output load resistor (R_L = 50 Ω) is connected to V_{ccR}-2.0V.
5. V_{ccR} = 3.3V, T_c=25 °C.
6. 20% - 80%.

Pin Diagram

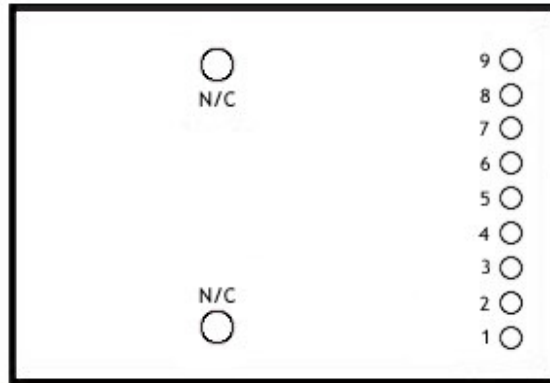

Pin Assignment

Pin No.	Symbol	Function	Type	Description
1	VeeR	Receiver Ground	Power Supply	Ground
2	RD+	Receiver Output Data	PECL Compatible Output	Receiver Output Data
3	RD-			Inverted Receiver Output Data
4	SD	Receiver Signal Detect	PECL Output	High = Optical Signal Present
5	VccR	Receiver Power	Power Supply	Positive Power Supply, +3.3V
6	VccT	Transmitter Power	Power Supply	Positive Power Supply, +3.3V
7	TD-	Transmitter Output Data	PECL Compatible Output	Inverted Transmitter Input Data
8	TD+			Transmitter Input Data
9	VeeT	Transmitter Ground	Power Supply	Ground
	N/C	Post	Mounting Posts	Not Connected

Recommended Interface Diagram

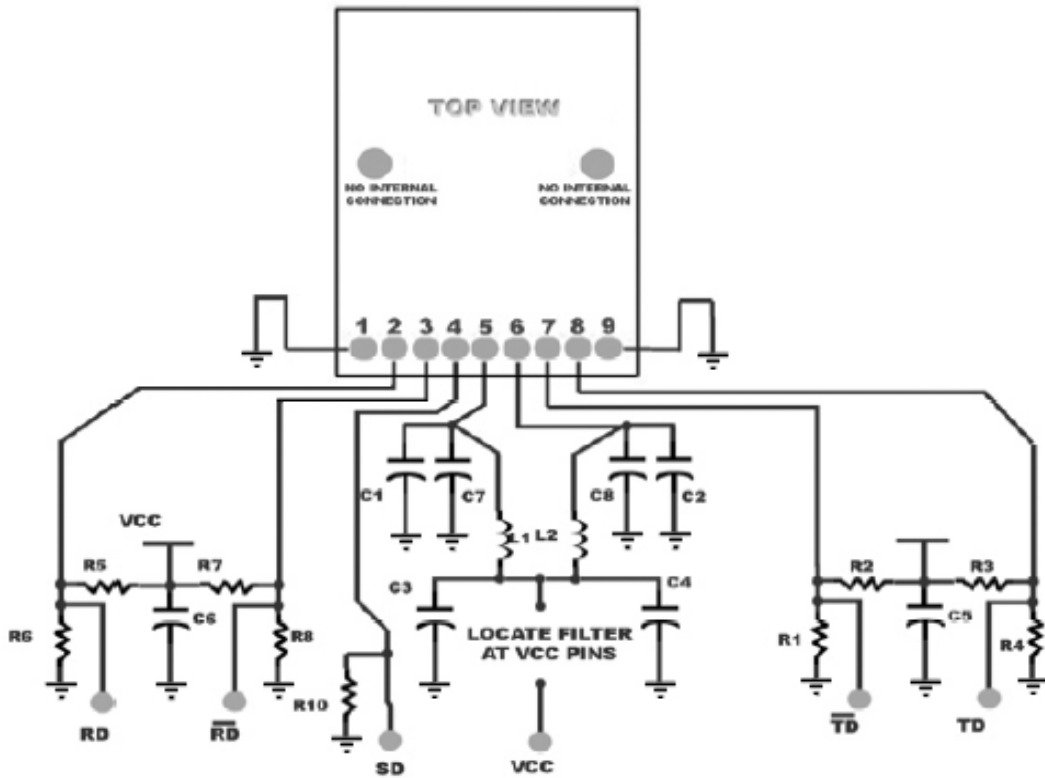

Note:

- These split-terminations for special signals need to be loaded at the input of device receiving PECL signals.

- R1 = R4 = R6 = R8 = 82 OHM
- R2 = R3 = R5 = R7 = 130 OHM
- C1 = C2 = 10 uF
- C3 = C4 = C7 = C8 = 100 nF
- C5 = C6 = 0.1 uF
- L1 = 12 = 3.3 uH COIL
- R10 = 270 OHM

Typical TX Side Eye Pattern

Diagram complies with ITU-T G.957 recommendations.

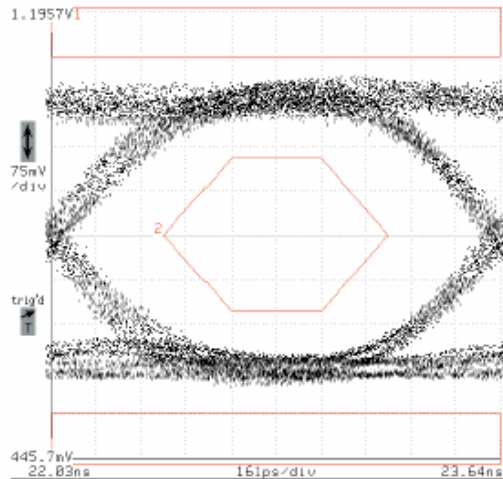

Package Outline Diagram

Dimensions for the device package are given in millimeters.

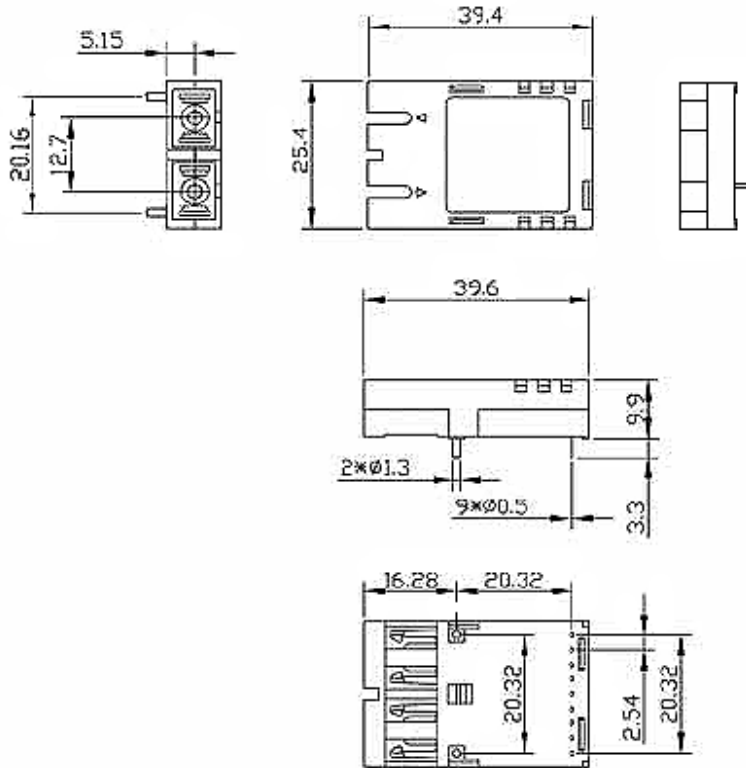

Additional Information

Contact

For additional information, product specifications, or information about Optocom:

Internet: <http://www.optocom.com>

Email: sales@optocom.com

Tel: +1 978 988 8711

Fax: +1 978 988 8722

©2005 Optocom Corporation. All rights reserved. Information in this document is believed to be accurate and reliable and is subject to change without notice. Optocom Corporation will not be held liable for technical or editorial errors or omissions contained herein. Reproduction in whole or in part is prohibited without prior written consent of the copyright owner and no responsibility will be assumed by Optocom Corporation for any infringements of third parties. All other brand or product names mentioned are the trademarks or registered trademarks owned by their respective companies or organizations.