

Fiber Optic SFP DFB OC-48 CWDM Transceiver with APD Photodiode

Data Sheet

OFP3478-XX



The OFP3478-XX transceiver module operates at wavelengths of 1470-1610 nm and at 2.5 Gb/s for CWDM, OC-48/STM-16 long reach applications.

Features

- Hot-pluggable
- Single +3.3 V supply
- Duplex LC connector interface
- CWDM Distributed Feedback (DFB) LD
- Low power dissipation
- OC-48/STM-16 Long Reach
- Multi data rates from 622Mbps to 2.7Gbps
- APD receiver
- 80 km link distance
- Operates in wavelengths of 1470/1490/1510/1530/1550/1570/1590/1610nm
- Multi-Source Agreement (MSA) for Small Form Factor Pluggable (SFP) Compliant

Applications

- Telecommunications and Data Communications system networks
- SONET OC-12, OC-48 LR-2/STM L16.2
- Gigabit Ethernet
- Point-to-Point networking
- Metro Access Rings
- 1x/ 2x Fiber Channel

Description

The OFP3478-XX transceiver provides signal conversion and processing for serial optical data communication applications. It operates over single mode fiber by converting lightwave information over specific wavelengths from 1470-1610nm into an electrical signal and vice versa at a data rate of 2.5 Gb/s.

Housed in a compact metal package, the transceiver module consists of a transmitter and receiver optical subassembly coupled with a duplex LC receptacle. A high-speed uncooled DFB laser diode operates as light source while an APD photodiode subsequently acts as a detector.

This dual-fiber connector transceiver is designed for use in CWDM, SONET OC-12, OC-48 LR-2/SDH STM-16 L16.2, Gigabit Ethernet and 1x/2x Fiber Channel applications at 2.5 Gb/s.

Serial Identification (EEPROM)

An SFP having module definition 4 provides access to sophisticated identification information that describes the SFP transceiver’s capabilities, standard interface, manufacturer and other information. An EEPROM containing the detailed product information for the host equipment is accessed by the 2-wire serial CMOS EEPROM protocol. See SFP MSA for detailed description.

Safety

Laser Compliance Statement

The OF3478-XX is classified as a Class I Laser Product and complies with IEC 60825-1 and FDA 21 CFR 1040.10 and 1040.11. The transceiver must be operated under recommended operating conditions. Because the transceiver is designed to be inherently eye safe, it does not require open fiber control thus eliminating complex electronics or mechanics.

Caution - use of device other than those specified herein may result in hazardous laser radiation exposure or other damage. Please embrace all customary precautions and discretion while handling this device.

Performance Specifications

Absolute Maximum Ratings

Stresses in excess of the absolute maximum ratings can cause damage to the optical device. Operations of the optical device are suggested to remain within the recommended operating conditions. Exposure to the absolute maximum ratings for extended periods can adversely affect device reliability.

Parameter	Symbol	Minimum	Maximum	Unit
Storage Temperature	T _S	-40	+85	°C
Supply Voltage	V _{CC}	0	4.0	V
Relative Humidity	RH	5	85	%

Recommended Operating Conditions

Parameter	Symbol	Minimum	Typical	Maximum	Unit
Operating Temperature	T _{OP}	0		70	°C
Supply Voltage	V _{CC}	3.1	3.3	3.5	V
Supply Current	I _{TX} + I _{RX}		200	300	mA

Transmitter Electro-Optical Interface (T_C = 0~70°C; V_{CC,T,R} = 3.1V < V_{CC} < 3.5V)

Parameter	Symbol	Minimum	Typical	Maximum	Unit
Transmitter Differential Input Voltage	TD +/-	400		2000	mVp-p
Optical Output Power ¹	P _O	0		+5	dBm
Optical Extinction Ratio ¹	E _R	8.2			dB
Center Wavelength ¹	λ _C	λ _C -6	λ _C	λ _C +7	nm
Spectral Width ¹	Δλ			< 1	nm
Side Mode Suppression Ratio ¹	SMSR	30			dB
Optical Rise/ Fall Time ²	t _r / t _f			0.15	nsec
Tx_Fault - HIGH	V _{Fault_H}	2		V _{CC}	V
Tx_Fault - LOW	V _{Fault_L}	V _{ee}		V _{ee} + 0.5	V
Tx_Disable - High	V _{Disable_H}	2		V _{CC}	V

OFF3478-XX SFP TRANSCEIVER DATA SHEET

Tx_Disable - LOW	$V_{Disable_L}$	V_{ee}	$V_{ee} + 0.8$	V
------------------	------------------	----------	----------------	---

Note:

1. Measured at 2488.32 Mbps, PRBS 2²³-1, NRZ.
2. 20%-80%

Receiver Electro-Optical Specifications ($T_C = 0\sim 70^\circ C$; $V_{CC,T,R} = 3.1V < V_{CC} < 3.5V$)

Parameter	Symbol	Minimum	Typical	Maximum	Unit
Receiver Differential Output Voltage	RD +/-	600	800		mV _{p-p}
Receiver Overload ^{1,2}	P_{INMAX}	-8			dBm
Receiver Sensitivity ^{1,2}	P_{INMAX}			-28	dBm
Operating Center Wavelength	λ_C	1270		1620	nm
Receiver LOS Assert Level ²	$P_{RX_LOS\ A}$	-45			dBm
Receiver LOS Deassert Level ²	$P_{RX_LOS\ D}$			-28.5	dBm
Receiver Loss of Signal Hysteresis ²		0.5	2		dB

Note:

1. With BER better than or equal to 1×10^{-12} .
2. Measured in center of eye opening with 2²³-1 PRBS, NRZ.

Pin Assignment

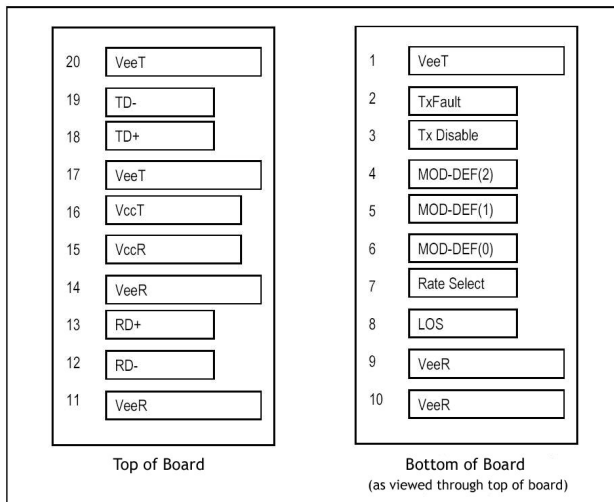

Figure 1. SFP Transceiver Electric Pad Layout

OFFP3478-XX SFP TRANSCEIVER DATA SHEET

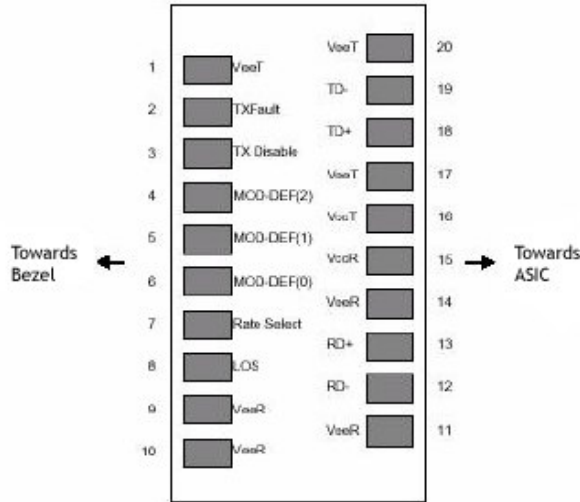

Figure 2. Diagram of Host Board Connector Block Pin

Pin Description and Plug-in Sequence¹ (1-Grd, 2-Power, 3-Signal)

Pin No.	Name	Description	Plug-in Sequence	Notes
1	VeeT	Transmitter Ground	1	Circuit ground is internally isolated from chassis ground.
2	TX Fault	Transmitter Fault Indication	3	Open-Collector outputs, asserted when LD and/or APC function fail.
3	TX Disable	Transmitter Disable	3	Disable when high voltage (>2.0V or Open).
4	MOD-DEF 2	Module Definition 2	3	Should be pulled up with 4.7k - 10 kΩ on host board to voltage between 2.0V and 5.5V. MOD-DEF (0) pulls line low to indicate module is plugged in.
5	MOD-DEF 1	Module Definition 1	3	See notes for Pin 4.
6	MOD-DEF 0	Module Definition 0	3	See notes for Pin 4.
7	Rate Select	Bandwidth Selection	3	No connection required.
8	LOS	Loss of Signal	3	LOS is Open-Collector output. Should be pulled up with 4.7k - 10kΩ on host board to a voltage between 2.0V and 5.5V. Logic 0 indicates normal operation; logic 1 indicates loss of signal.
9	VeeR	Receiver Ground	1	See notes for Pin 1.
10	VeeR	Receiver Ground	1	See notes for Pin 1.
11	VeeR	Receiver Ground	1	See notes for Pin 1.
12	RD-	Inv. Received Data Out	3	
13	RD+	Received Data Out	3	
14	VeeR	Receiver Ground	1	See notes for Pin 1.
15	VccR	Receiver Power	2	
16	VccT	Transmitter Power	2	

0FP3478-XX SFP TRANSCEIVER DATA SHEET

17	VeeT	Transmitter Ground	1	See notes for Pin 1.
18	TD+	Transmit Data In	3	
19	TD-	Inv. Transmit Data In	3	
20	VeeT	Transmitter Ground	1	See notes for Pin 1.

Note:

1. Pin engagement sequence during hot plugging.

Physical Characteristics

Outline Diagram

Dimensions for the device package are given in millimeters.

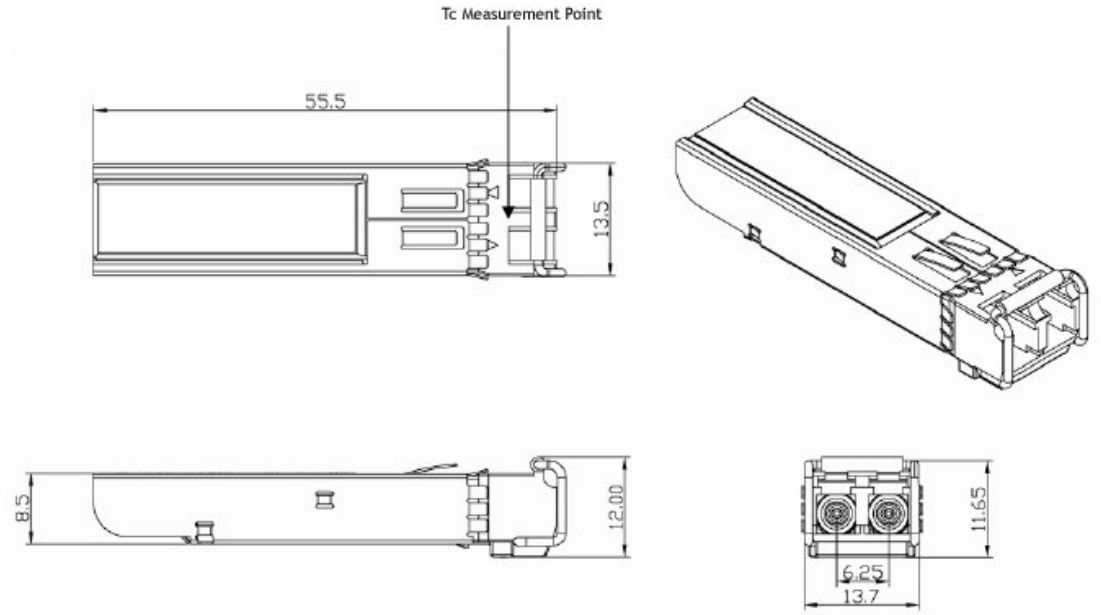

Application Circuits

Recommended Host Board Supply Filtering Network

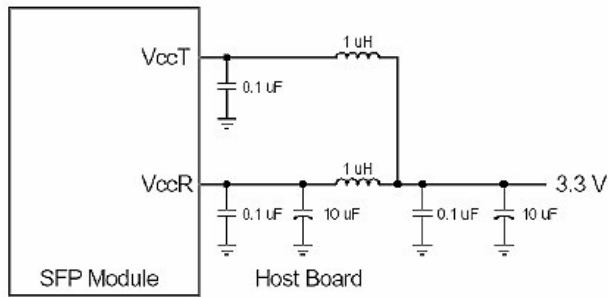

Recommended Interface Diagram

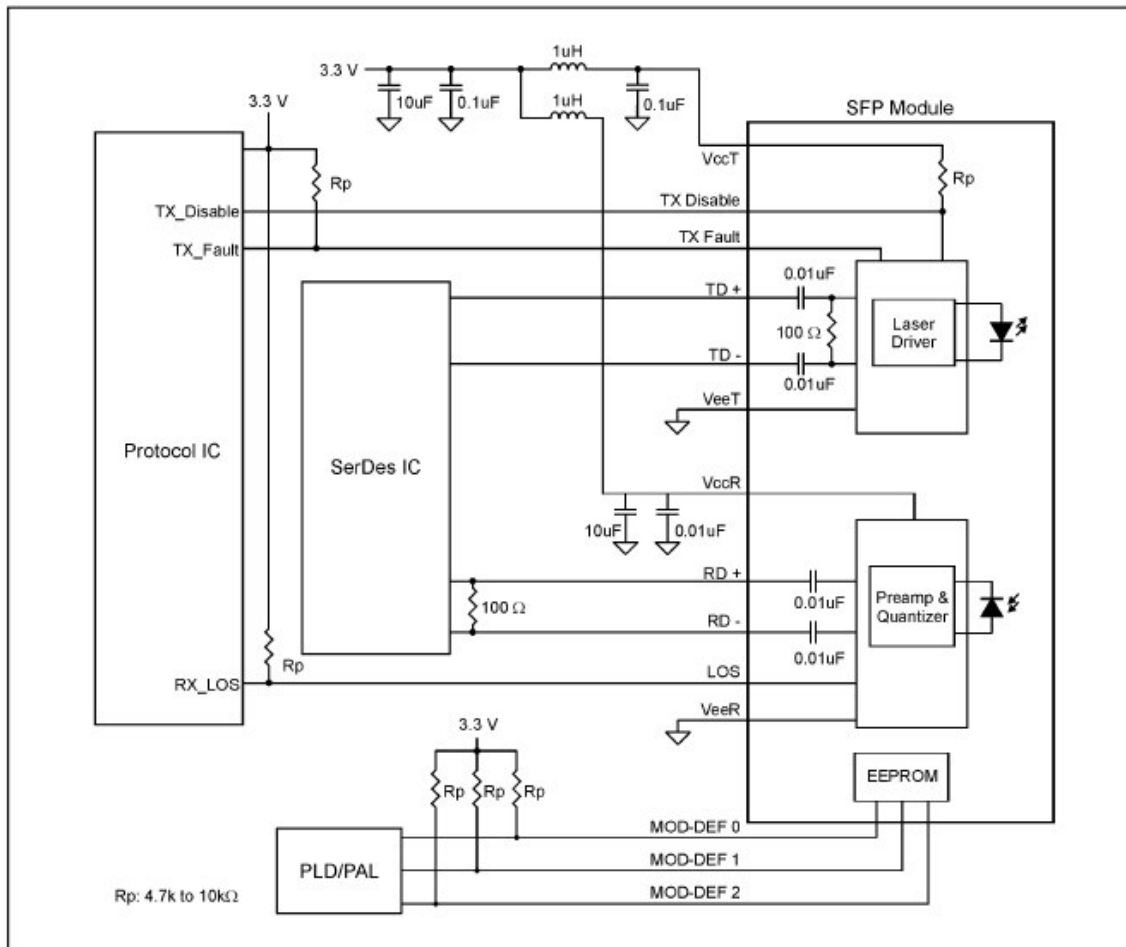

Additional Information

Ordering Information

Center Wavelength	Part Number
1470 nm	OFP3478-47
1490 nm	OFP3478-49
1510 nm	OFP3478-51
1530 nm	OFP3478-53
1550 nm	OFP3478-55
1570 nm	OFP3478-57
1590 nm	OFP3478-59
1610 nm	OFP3478-61

Contact

For additional information, product specifications, or information about Optocom:

Internet: <http://www.optocom.com>
Email: sales@optocom.com
Tel: +1 978 988 8711
Fax: +1 978 988 8722

©2005 Optocom Corporation. All rights reserved. Information in this document is believed to be accurate and reliable and is subject to change without notice. Optocom Corporation will not be held liable for technical or editorial errors or omissions contained herein. Reproduction in whole or in part is prohibited without prior written consent of the copyright owner and no responsibility will be assumed by Optocom Corporation for any infringements of third parties. All other brand or product names mentioned are the trademarks or registered trademarks owned by their respective companies or organizations.