

Fiber Optic GBIC 1550nm DFB 1.25G Lightwave Transceiver

Data Sheet

OGB3357



The OGB3357 transceiver module operates a wavelength of 1550 nm and at 1.25 Gb/s for 1000BASE-ZX.

Features

- Hot-pluggable
- Single +3.3 V to +5.0 V supply
- SC duplex interface, singlemode fiber
- 60 km link distance
- 1550nm uncooled DFB laser diode
- Low Power Dissipation
- Metal enclosure, low EMI
- IEEE 802.3z Gigabit Ethernet 1000BASE-ZX compliant
- Fiber Channel compliant
- SFF-8053 Gigabit Interface Converter (GBIC) Specification compliant

Applications

- Telecommunications and Data Communications system networks
- Gigabit Ethernet
- 1x Fiber Channel
- Metro Access Rings
- Point-to-Point Channel

Description

The OGB3357 transceiver provides signal conversion and processing for serial optical data communication applications. It operates over singlemode fiber by converting lightwave information into an electrical signal and vice versa at a data rate of 1.25 Gb/s.

The Gigabit singlemode transceiver is a single unit comprised of a transmitter, a receiver, and a duplex SC receptacle. The high-speed uncooled DFB laser diode and a photodiode are provided as a light source and a detector, respectively. This transceiver features hot-pluggable function and is specially developed for distances of up to 60 km.

This dual-fiber connector transceiver is designed for use in LAN, SAN, WAN at 1.25 Gb/s from a single power supply (+3.3 V to +5.0 V) for Gigabit Ethernet 1000BASE-ZX and Fiber Channel applications.

Serial Identification (EEPROM)

A GBIC transceiver having module definition 4 provides access to sophisticated identification information that describes the GBIC transceiver’s capabilities, standard interface, manufacturer and other information. An EEPROM containing the detailed product information for the host equipment is accessed by the 2-wire serial CMOS EEPROM protocol of the ATMEL AT24C01A. See GBIC specification (SFF-8053) for detailed description.

Safety

Laser Compliance Statement

The OGB3357 is classified as a Class I Laser Product. It complies with IEC 60825-1 and FDA 21 CFR 1040.10 and 1040.11. The transceiver must be operated under recommended operating conditions. Because the transceiver is designed to be inherently eye safe, it does not require open fiber control thus eliminating complex electronics or mechanics.

Caution - use of device other than those specified herein may result in hazardous laser radiation exposure or other damage. Please embrace all customary precautions and discretion while handling this device.

Performance Specifications

Absolute Maximum Ratings

Stresses in excess of the absolute maximum ratings can cause damage to the optical device. Operations of the optical device are suggested to remain within the recommended operating conditions. Exposure to the absolute maximum ratings for extended periods can adversely affect device reliability.

Parameter	Symbol	Minimum	Maximum	Unit
Storage Temperature	T _S	-40	+85	°C
Power Supply Voltage	V _{CC}	0	6.0	V
Relative Humidity	RH	5	85	%

Recommended Operating Conditions

Parameter	Symbol	Minimum	Typical	Maximum	Unit
Operating Temperature	T _{OP}	0		70	°C
Supply Voltage	V _{CC}	3.1	3.3	5.25	V
Supply Current (I _{TX} + I _{RX})	I _{CC}		200	300	mA

Transmitter Electro-Optical Interface (T_C = 0 ~ 70°C; V_{CC}T,R = 3.1V < V_{CC} < 5.25V)

Parameter	Symbol	Minimum	Typical	Maximum	Unit
Transmitter Differential Input Voltage	TD +/-	400		2000	mVp-p
Optical Output Power ¹	P _o	-2		+3	dBm
Optical Extinction Ratio ¹	E _r	9			dB
Center Wavelength ¹	λ _C	1530		1570	nm
Spectral Width (-20dB) ¹	Δλ			<1	nm
Side Mode Suppression Ratio ¹	SMSR	30			dB
Rise Time/ Fall Time ²	t _R / t _F			0.25	nsec
Tx_Fault - HIGH	V _{Fault_H}	2		V _{CC}	V
Tx_Fault - LOW	V _{Fault_L}	V _{ee}		V _{ee} +0.5	V
Tx_Disable - HIGH	V _{Disable_H}	2		V _{CC}	V
Tx_Disable - LOW	V _{Disable_L}	V _{ee}		V _{ee} +0.8	V

OGB3357 GBIC TRANSCEIVER DATA SHEET

Notes:

1. Measured at 1250 Mbps, PRBS 2⁷-1, NRZ.
2. 20% - 80%.

Receiver Electro-Optical Specifications (T_c = 0 ~ 70 °C; V_{CC}T,R = 3.1V < V_{CC} < 5.25V)

Parameter	Symbol	Minimum	Typical	Maximum	Unit
Receiver Differential Output Voltage	RD +/-	600	800		mVp-p
Receiver Overload ^{1,2}	P _{IN} MAX	-3			dBm
Receiver Sensitivity at 1.25 Gbps ^{1,2}	P _{IN} MIN		-24	-18	dBm
Operating Center Wavelength	λ _C	1270		1620	nm
Receiver LOS Assert Level ²	P _{RX_LOS A}	-35			dBm
Receiver LOS Deassert Level ²	P _{RX_LOS D}			-18.5	dBm
Receiver Loss of Signal Hysteresis ²		0.5	2		dB

Notes:

1. With BER better than or equal to 1x10⁻¹².
2. Measured in the center of the eye opening with 2⁷-1 PRBS, NRZ.

Connector

Optical Connector: Duplex SC receptacle

Electrical Connector: 20 PIN SCA-2

Pin Assignment and Plug-in Sequence¹ (1-Gnd and Signal; 2-Power)

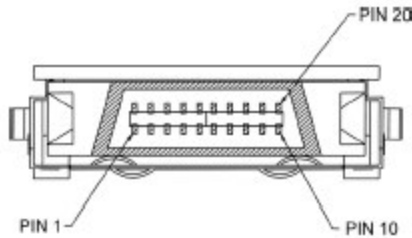

Pin No.	Name	Description	Input/Output	Notes
1	Rx_LOS	Receiver Loss of Signal	OUT	5
2	RGND	Receiver Ground		1
3	RGND	Receiver Ground		1
4	MOD-DEF 0	TTL LOW	OUT	4
5	MOD-DEF 1	SCL Serial Clock Signal	IN	4
6	MOD-DEF 2	SDA Serial Clock Signal	IN/ OUT	4
7	Tx_Disable	Transmitter Disable	IN	3
8	TGND	Transmitter Ground		1
9	TGND	Transmitter Ground		1
10	Tx_Fault	Transmitter Fault Indication	OUT	2
11	RGND	Receiver Ground		1
12	-Rx_DAT	Receiver Data Differential PECL ac-coupled	OUT	
13	+Rx_DAT	Receiver Data Differential PECL ac-coupled	OUT	
14	RGND	Receiver Ground		1
15	VccR	Receiver Supply	IN	

OGB3357 GBIC TRANSCEIVER DATA SHEET

16	VccT	Transmitter Supply	IN	
17	TGND	Transmitter Ground		1
18	+Tx_DAT	Transmit Data Differential PECL ac-coupled	IN	
19	-Tx_DAT	Transmit Data Differential PECL ac-coupled	IN	
20	TGND	Transmitter Ground		1

Note:

1. Circuit ground is internally isolated from chassis ground.
2. Open-Collector outputs, asserted when LD and/or APC function fails.
3. Disable when high voltage (>2.0V or open).
4. Should be pulled up with 4.7k-10kΩ on host board to a voltage between 2.0V and 5.5V. MOD_DEF (0) pulls line low to indicate module is plugged in.
5. LOS is open collector output. Should be pulled up with 4.7k-10kΩ on host board to a voltage between 2.0V and 5.5V. Logic 0 indicates normal operation; logic 1 indicates loss of signal.

Physical Characteristics

Outline Diagram

Dimensions for the device package are given in millimeters.

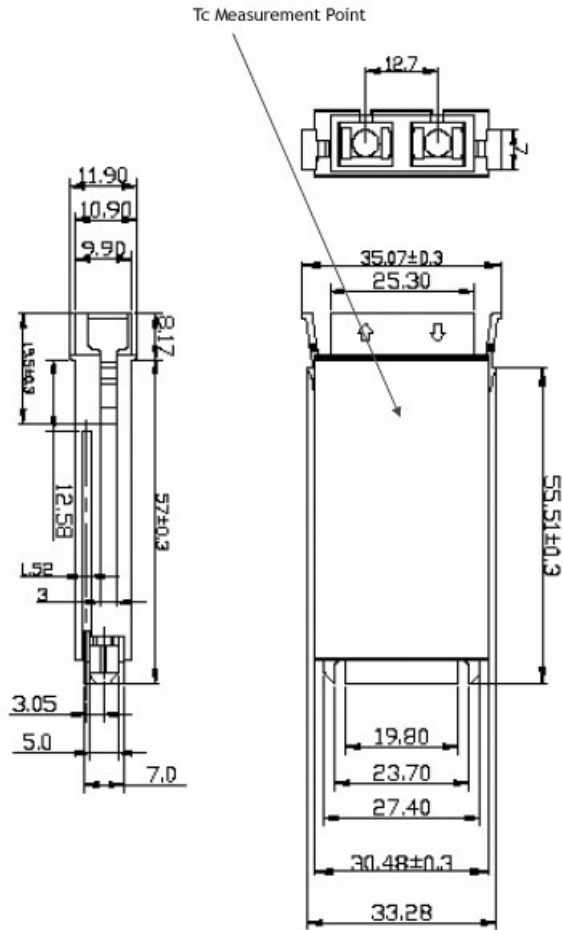

Recommended Interface Diagram

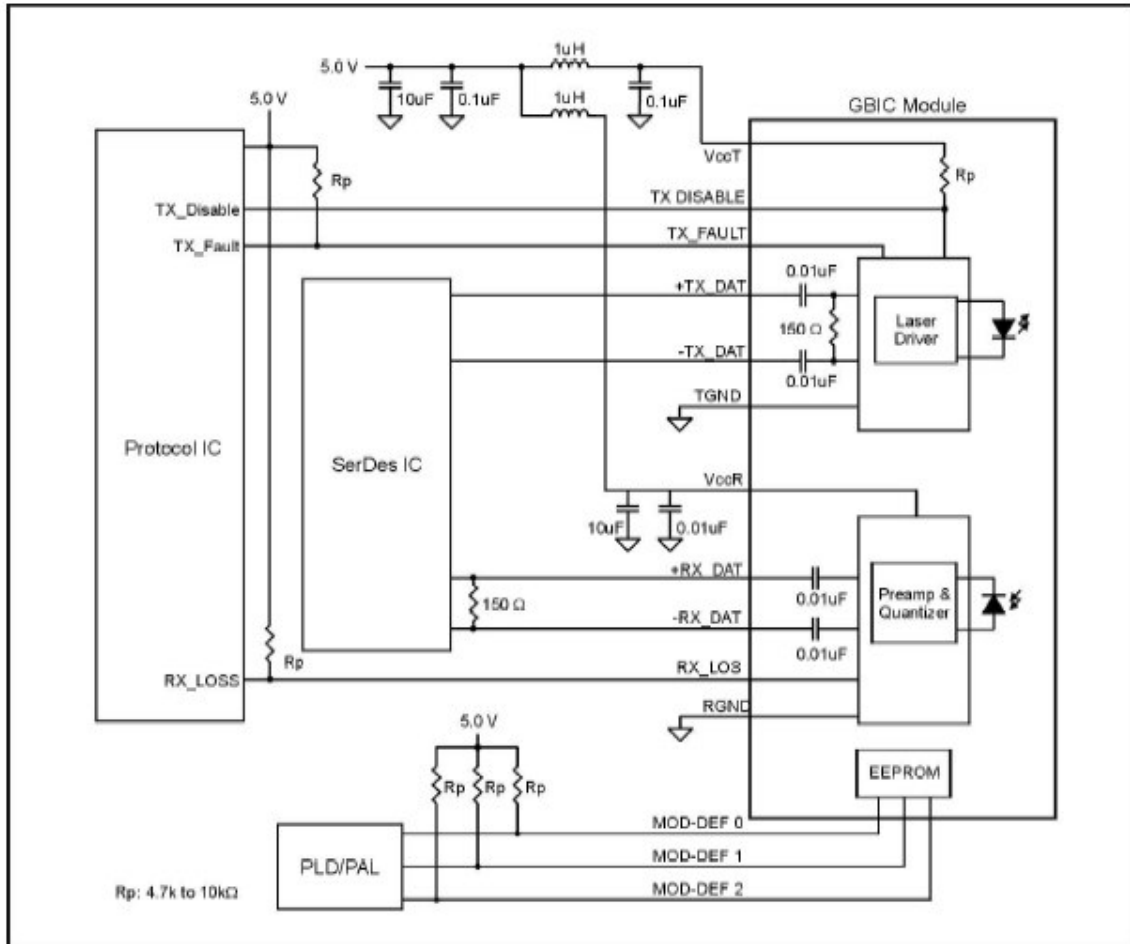

Additional Information

Contact

For additional information, product specifications, or information about Optocom:

Internet: <http://www.optocom.com>

Email: sales@optocom.com

Tel: +1 978 988 8711

Fax: +1 978 988 8722

©2005 Optocom Corporation. All rights reserved. Information in this document is believed to be accurate and reliable and is subject to change without notice. Optocom Corporation will not be held liable for technical or editorial errors or omissions contained herein. Reproduction in whole or in part is prohibited without prior written consent of the copyright owner and no responsibility will be assumed by Optocom Corporation for any infringements of third parties. All other brand or product names mentioned are the trademarks or registered trademarks owned by their respective companies or organizations.