

1310 nm FP 1.25G Laser Diode Module With Pigtail Connection

Data Sheet

OLD2333-E5

Features

- Uncooled
- Type A laser
- Low threshold current
- Output power: 0.4mW
- Data Rate: 1.25 Gbps
- Horizontal flange
- 1310nm Fabry-Perot laser diode
- InGaAs monitor PIN photodiode
- Single mode fiber pigtail
- Operating Temperature: -40~ +85°C

Applications

- Digital Signal Transmission
- Telecommunications (Local loop, interoffice and intraoffice)
- Data Communications
- Gigabit Ethernet
- SONET OC-3, OC-12, OC-24/SDH STM-1, STM-4, STM-8
- Insertion/ Return loss meter

Description

The OLD2333-E5 is a hermetically sealed InGaAsP/ InP Fabry-Perot laser diode module in a small coaxial type package, including a high speed InGaAs PIN monitor photodiode and single mode fiber pigtail connection. It comes with a horizontal flange.

The laser diode is designed for use in data communications systems and telecommunications systems over single mode fiber, and can operate in temperatures of -40°C to 85°C. The laser diode module transmits emission power to the monitor photodiode in the rear, which ensures highly stable emission at a wavelength of 1310 nm.

Safety

Radiation emitted by laser diode devices can be dangerous to the eyes. Avoid direct or scattered radiation exposure to the eyes or skin. Device contains gallium arsenide (GaAs) which can be hazardous to your health. Please embrace all customary precautions and discretion while handling this device. Observe governmental laws and regulations when discarding this device.

Performance Specifications

Absolute Maximum Ratings

Stresses in excess of the absolute maximum ratings can cause damage to the optical device. Operations of the optical device are suggested to remain within the recommended operating conditions. Exposure to the absolute maximum ratings for extended periods can adversely affect device reliability.

Parameter	Symbol	Value	Unit
Storage Temperature	T_{stg}	-40 to +85	°C
Operating Case Temperature	T_{op}	-40 to +85	°C
Peak Optical Output Power	P_o	5	mW
Forward Current (LD)	I_{FLD}	100	mA
Reverse Voltage (LD)	V_{RLD}	2	V
Reverse Current (PD)	I_{RPD}	2	mA
Reverse Voltage (PD)	V_{RPD}	15	V
Soldering Temperature	Stemp	260	°C
Soldering Time	Stime	10	sec

Electrical and Optical Characteristics ($T_c=25^\circ\text{C}$)

Parameter	Symbol	Condition	Min	Typ	Max	Unit
Central Wavelength	λ_c	CW, Pf	1280	1310	1340	nm
Spectral Width	$\Delta\lambda$	CW, Pf	-	2	5	Nm
Threshold Current	I_{th}	CW	-	10	15	mA
Fiber Output Power	Pf	CW, IF+35mA	0.4	-	-	mW
Operating Voltage	V_{op}	Pf	-	1.2	1.6	V
Rise Time/ Fall Time	T_r/T_f	$I_b=I_{th}$, 20%-80%	-	0.3	0.7	ns
Monitor Current	I_m	Pop, $V_{rp}=5V$	0.1	-	-	mA
Monitor Dark Current	I_d	$V_{rp}=5V$	-	40	100	nA
Monitor Capacitance	C	$V_{rp}=5V$, $f=1MHz$	-	10	20	pF
Tracking Error	Pf/Pf	APC, -40 to +85°C	-	±1.0	-	dB

Package Outline Diagram

Dimensions for the device package are given in millimeters.

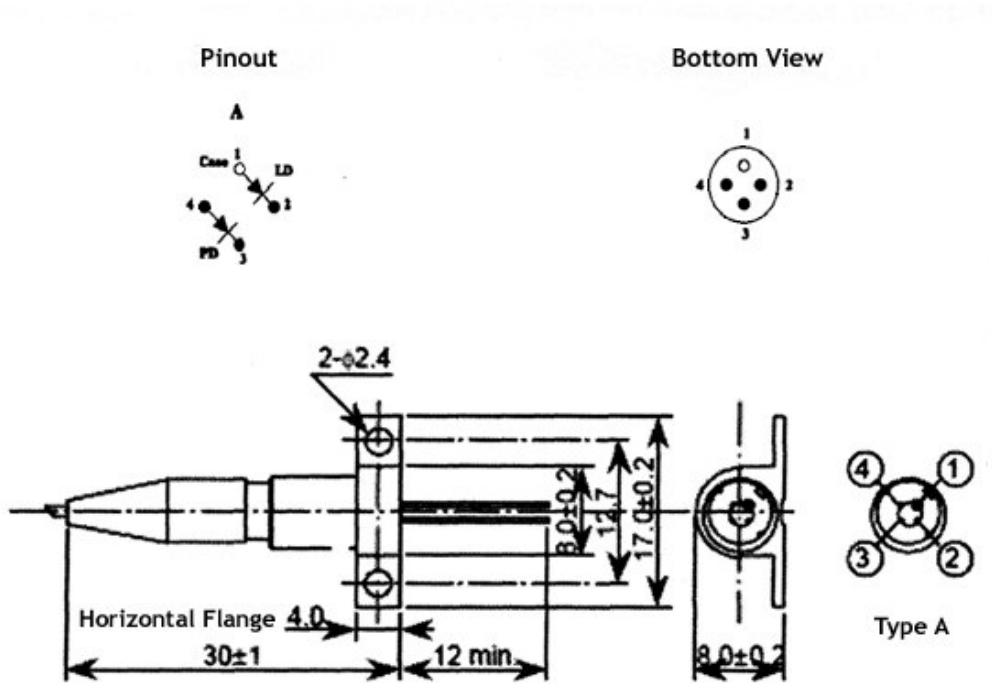

Additional Information

Contact

For additional information, product specifications, or information about Optocom:

Internet: <http://www.optocom.com>

Email: sales@optocom.com

Tel: +1 978 988 8711

Fax: +1 978 988 8722