

Fiber Optic SFF 2x5 1310 nm FP 155 Mbps Lightwave Transceiver

Data Sheet

OSF2131-A

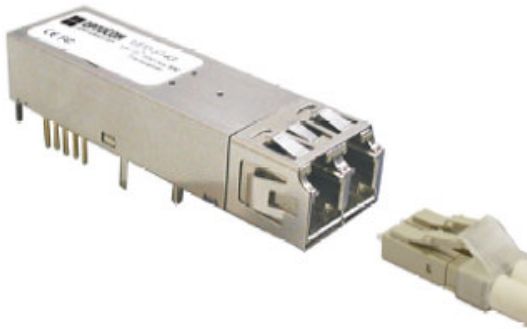

Features

- 1310 nm FP
- Operating Temperature from -40 to +85°C
- LC Duplex interface
- Single power supply (+3.3V)
- Industry standard Small Form Factor (SFF) package
- 2 km link distance
- PECL differential inputs and outputs
- Signal Detect (SD) PECL compatible
- Multisource 2x5 footprint
- Small footprint for high channel density
- 10 Mbps Ethernet compliant
- Fast Ethernet IEEE 802.3u compliant
- ESD Class 2 per MIL-STD 883 Method 3015
- FCC (Class B) and EN 55022 compliant
- FDDI PMD compliant

Applications

- Metro-Access Rings
- Fiber-to-the-Desktop
- ATM/SONET OC-3/SDH STM-1
- Switches/bridges/routers/servers
- 10 Mbps Ethernet
- Fast Ethernet
- Local Area Network (LAN)
- Point-to-point networking
- FDDI
- High-speed computer links

Description

The OSF2131-A transceiver provides signal conversion and processing for serial optical data communication applications. It operates over singlemode fiber by converting lightwave information into an electrical signal and vice versa at a data rate of 155 Mb/s.

The transceiver is a single unit comprised of a transmitter, a receiver, and a duplex LC receptacle. This transceiver conforms to the Small Form Factor (SFF) Multi-Source Agreement (MSA) in 2x5 footprint and is specially developed for distances of up to 2 km with singlemode or multimode fibers.

This dual-fiber connector transceiver is designed for use from a single power supply (+3.3 V) for 10 Mbps Ethernet, Fast Ethernet, FDDI, and ATM/SONET applications.

Safety

Laser Compliance Statement

The OSF2131-A is classified as a Class I Laser Product. It complies with IEC 60825-1 and FDA 21 CFR 1040.10 and 1040.11. The transceiver must be operated under recommended operating conditions. Because the transceiver is designed to be inherently eye safe, it does not require open fiber control thus eliminating complex electronics or mechanics.

Caution - use of device other than those specified herein may result in hazardous laser radiation exposure or other damage. Please embrace all customary precautions and discretion while handling this device.

Performance Specifications

Absolute Maximum Ratings

Stresses in excess of the absolute maximum ratings can cause damage to the optical device. Operations of the optical device are suggested to remain within the recommended operating conditions. Exposure to the absolute maximum ratings for extended periods can adversely affect device reliability.

Parameter	Symbol	Minimum	Maximum	Unit
Supply Voltage	V _{CC} T V _{CC} R	0	4.0	V
Storage Ambient Temperature	T _{STG}	-40	+95	°C
Relative Humidity	R _H	5	85	%

Recommended Operating Conditions

Parameter	Symbol	Minimum	Typical	Maximum	Unit
Operating Temperature	T _{OP}	-40		+85	°C
Supply Voltage	V _{CC} T,R	3.1	3.3	3.5	V
Supply Current	I _{TX} +I _{RX}		200	300	mA

Transmitter Electro-Optical Characteristics (T_C=-40~85 °C, V_{CC}T,R=3.1V<V_{CC}<3.5V)

Parameter	Symbol	Minimum	Typical	Maximum	Unit
Transmitter Differential Input Voltage	TD +/-	400		2000	mVp-p
Optical Output Power ¹	P _O	-20		-6	dBm
Optical Extinction Ratio ¹	E _r	9			dB
Center Wavelength ¹	λ _C	1260		1360	nm
Spectral Width ¹	Δλ			<3	nm
Optical Rise/Fall Time, 20%-80%	t _R / t _F			2.5	ns
Tx_Fault - HIGH	V _{Fault_H}	2		V _{CC}	V
Tx_Fault - LOW	V _{Fault_L}	V _{EE}		V _{EE} +0.5	V
Tx_Disable - HIGH	V _{Disable_H}	2		V _{CC}	V
Tx_Disable - LOW	V _{Disable_L}	V _{EE}		V _{EE} +0.8	V

Note:

1. Measured at 155.52 Mbps, PRBS 2²³-1, NRZ.

Receiver Electro-Optical Specifications ($T_C=-40\sim 85^\circ\text{C}$, $V_{ccT,R}=3.1\text{V}<V_{cc}<3.5\text{V}$)

Parameter	Symbol	Minimum	Typical	Maximum	Unit
Receiver Differential Output Voltage	RD +/-	600	800		mVp-p
Receiver Overload	P_{INMAX}	-6			dBm
Receiver Sensitivity	P_{INMIN}			-31	dBm
Operating Center Wavelength	λ_c	1270		1620	nm
Receiver LOS Assert Level	$P_{RX_LOS A}$	-45			dBm
Receiver LOS Deassert Level	$P_{RX_LOS D}$			-31.5	dBm
Receiver Loss of Signal Hysteresis		0.5	2		dB

Notes:

1. For a bit error rate (BER) of less than or equal to 1×10^{-12} .
2. Measured in the center of the eye opening with $2^{23}-1$ PRBS, NRZ.

Pin Assignment

Function	Pin#	Diagram
RxVEE	1	<p>Top View</p>
RxVCC	2	
SD	3	
RD-	4	
RD+	5	
TxVCC	6	
TxVEE	7	
Disable	8	
TD+	9	
TD-	10	

Interface Circuit Diagram

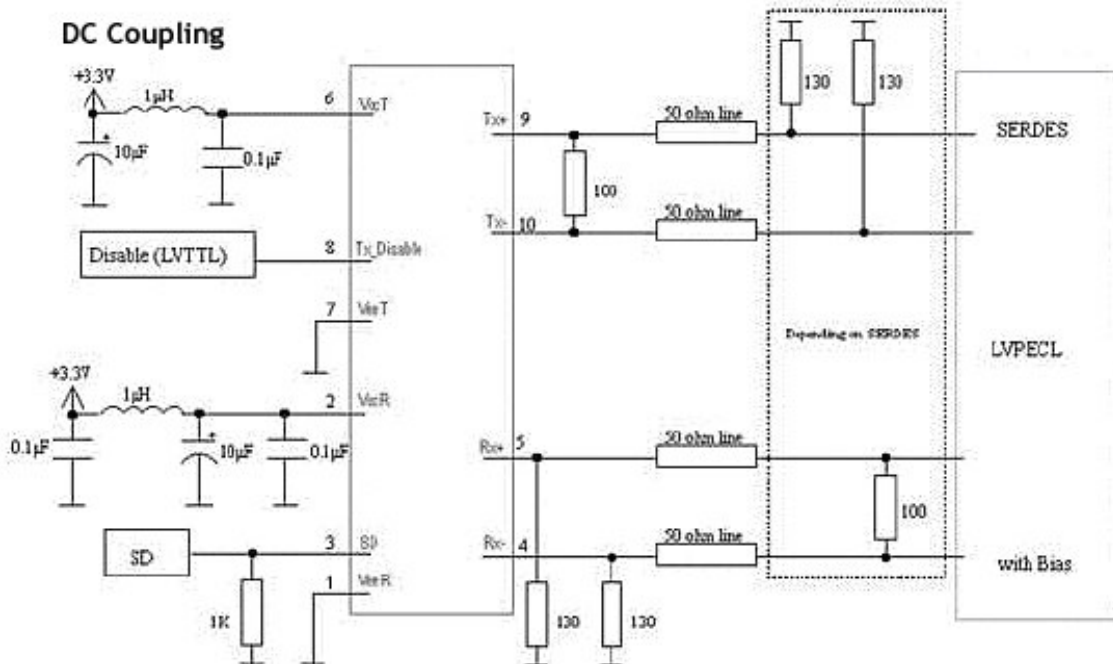

OSF2131-A SFF 2x5 TRANSCEIVER DATA SHEET

Notes:

1. To disable transmitter, apply LV-TTL Logic High.
2. All 0.1 μ F power supply bypass capacitors should be as close to transceiver module as possible.
3. If SIGNAL_DETECT is LV_TTL, a termination resistor of 1k ohm to GND is not required.

Physical Characteristics

Outline Diagram

Dimensions for the device package are given in millimeters.

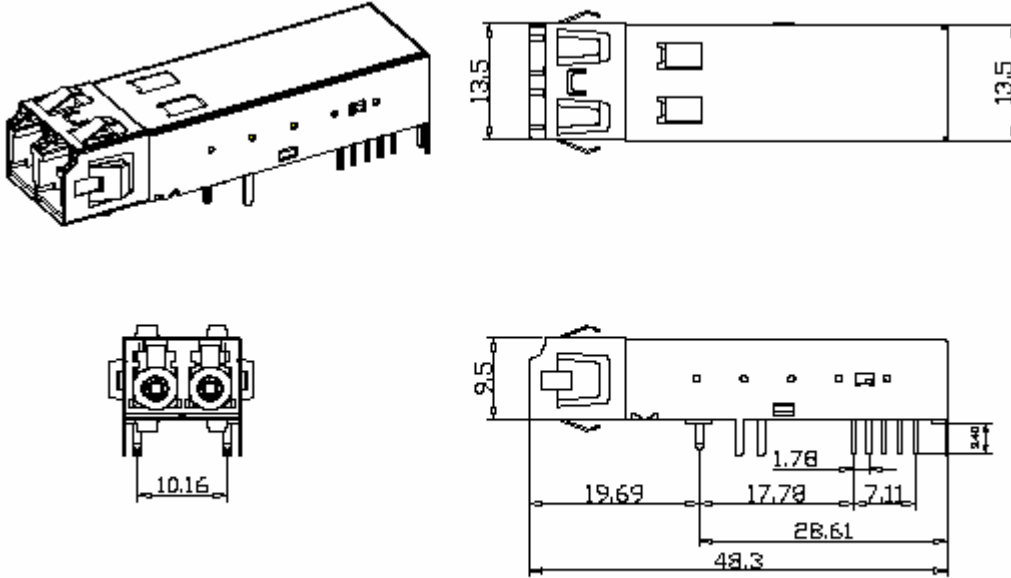

Additional Information

Contact

For additional information, product specifications, or information about Optocom:

Internet: <http://www.optocom.com>

Email: sales@optocom.com

Tel: +1 978 988 8711

Fax: +1 978 988 8722

©2005 Optocom Corporation. All rights reserved. Information in this document is believed to be accurate and reliable and is subject to change without notice. Optocom Corporation will not be held liable for technical or editorial errors or omissions contained herein. Reproduction in whole or in part is prohibited without prior written consent of the copyright owner and no responsibility will be assumed by Optocom Corporation for any infringements of third parties. All other brand or product names mentioned are the trademarks or registered trademarks owned by their respective companies or organizations.