

Please read this data sheet before purchasing, and keep it on file for future reference. It contains important information on the product specifications.

Optocom

Optoelectronics Group

OPT1475-5.Ø

OC-48 Optical Receiver

Data Sheet

2004/5



210 Andover Street, Wilmington, MA 01887

Contents

General	3	Description
	3	Applications
	3	Standards Met
Features	3	Operation
	3	User Options and Assurance
Ratings	3	Absolute Maximum Ratings
Operating Characteristics	4	Optical
	4	Electrical
	5	Interface Diagram
Physical	5	Outline Diagram
	6	Dimensions
	6	Connections
	6	Pin Designations
Safety	7	Optical
	7	Electrical
	7	Other
Appendix	7	Terms
Additional Information	7	Contact

©2002-2005 Optocom Corporation. All rights reserved. Reproduction in whole or in part is prohibited without prior written consent of the copyright owner. The information presented in this document does not form part of any quotation or contract and is believed to be accurate and reliable and may be subjected to change without notice. No liability will be accepted by the publisher for any consequence of its use.

General

Description

The OPT1475-5.Ø is a 20-pin DIP fiber optic receiver module which converts lightwaves in the 1310/1550 nm band to electrical data signals at a data rate of 20 Mbps to 2.5 Gbps. The receiver has a hermetically sealed InGaAs avalanche photodiode aligned to a singlemode fiber.

Applications

The device is designed for data communication systems and telecommunication transmission systems over singlemode or multimode fiber.

Standards Met

The specifications met are: the SONET/SDH STS-48/STM-16 interface, the Long Reach OC-48 Optical Parameters (LR-1, LR-2 & LR-3) of Bellcore GR-253-CORE, the Long-haul Recommendation (L-16.1, L-16.2 & L-16.3) of ITU-T G.957, and the monitor & alarm requirements of Bellcore GR-253-CORE & ITU-T G.783 and G.958.

Ratings

Absolute Maximum Ratings

Parameter	Symbol	Min	Max	Unit
Supply Voltage	V_{CC}	0	6.0	V
Photodiode Supply Voltage	V_{PD}	0	V_B	V
Operating Case Temperature Range	T_C	-40	85	°C
Operating Relative Humidity (non-condensing)	H_{OP}	---	85	%
Lead Soldering Temperature/Time	T/t	---	250/10	°C/s
Minimum Fiber Bend Radius	R_F	32/1.25	---	mm/in.
Storage Case Temperature Range	T_{SIG}	-40	85	°C

Features

Operation

The OPT1475-5.Ø optical receiver operates using a single +5 V and an APD bias power supply. The device maintains electrical and optical stability over the specified temperature and voltage ratings.

User Options and Assurance

Operator can measure the photocurrent generated in response to the incoming optical signal. The photocurrent can be calculated based on the voltage drop across an external resistor connected between the monitoring pin 10 and APD supply voltage. If photocurrent measurement is not required, pin 10 should be connected to an APD power supply directly.

Every device is optically and electrically tested to ensure highest performance and reliability.

Operating Characteristics

Optical

Parameter	Symbol	Min	Typ	Max	Unit
Input Wavelength	λ	1000	---	1650	nm
Measured Average Sensitivity ¹	P_{RL}	-28	---	---	dBm
Maximum Input Power	P_{RH}	-5.0	---	---	dBm
Signal Detect Threshold:					
Decreasing Light Input	SDT_D	---	---	-28	dBm
Increasing Light Input	SDT_I	---	---	-28	dBm
Photodiode Responsivity ² ($\lambda=1310$ nm)	PD_R	0.7	0.8	---	A/W
Photodiode Responsivity ² ($\lambda=1550$ nm)	PD_R	0.8	0.9	---	A/W
APD Photodiode Breakdown Voltage	V_B	40	65	100	V
Temperature Coefficient of V_B	γ	---	0.17	---	%/°C

¹ At a BER of 1×10^{-10} and an extinction ratio of 8.2 dB or more.

² Photocurrent 1 = Responsivity x Mean Power.

Electrical

Parameter	Symbol	Min	Typ	Max	Unit
dc Power Supply Voltage	V_{CC}	4.75	5.0	5.25	V
dc Power Supply Current	I_{CC}	50	80	150	mA
Output Voltage¹:					
Low	V_{OL}	-1.84	---	-1.62	V
High	V_{OH}	-1.10	---	-0.90	V
Output Rise/Fall Time	t_R/t_F	---	100	155	ps
Output Flag Voltage¹:					
Low	V_{FL}	-1.84	---	-1.62	V
High	V_{FH}	-1.10	---	-0.90	V
Output Data Current:					
Low	I_{OL}	---	5	50	mA
High	I_{OH}	---	20	50	mA
Output Flag Current:					
Low	I_{FL}	---	10	15	mA
High	I_{FH}	---	10	15	mA

¹ Output measured relative to V_{CC} with interface shown in Figure 1.

Operating Characteristics - continued

Figure 1. Interface Diagram

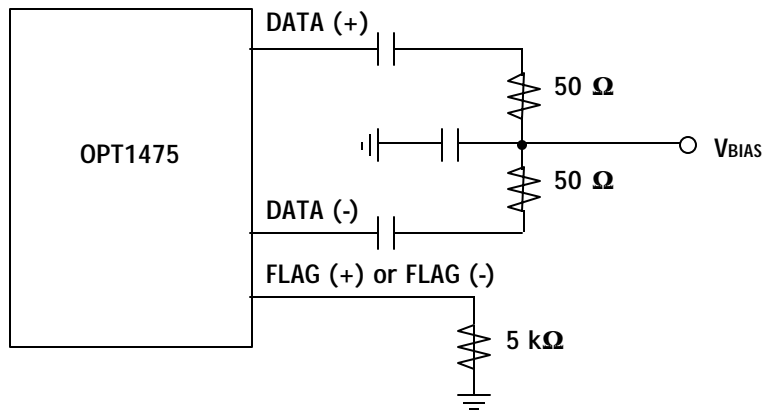

Physical

The device package conforms to the 20-pin DIP outline shown below.

Figure 2. Outline Diagram

Outline Diagram

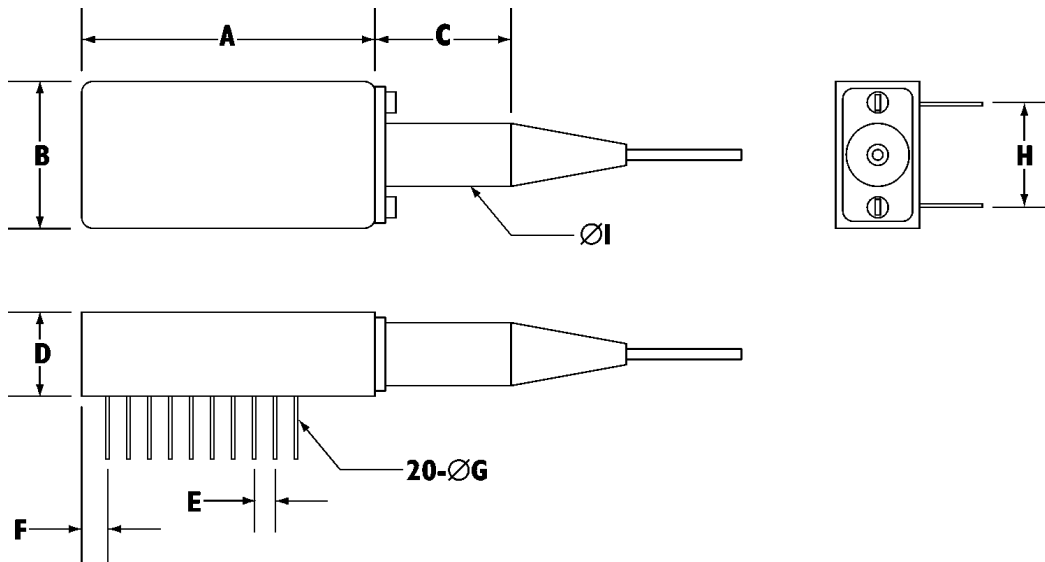

Physical - continued

Dimensions

Dimension	Typ	
	Inches	Metric (mm)
A	1.300	33.0
B	0.635	16.13
C	1.22	30.99
D	0.365	9.27
E	0.100	2.54
F	0.110	2.79
ØG	0.018	0.46
H	0.400	10.16
ØI	0.236	6.00

An assigned serial number in both barcode and human readable formats appear on the device. All markings and labels are permanent and meet the requirements of MIL-STD-883C-2015.7.

Connections

The pigtail consists of a singlemode (SM) fiber with an 8 μm core. The outer jacket has a nominal 900 μm outer diameter and is terminated with an ST^{®*}, FC, or SC Connector. The minimal pigtail length is 1 meter (39.4 inches) long.

*ST[®] is a registered trademark of AT&T

Pin Designations

Pin	1	2	3	4	5	6	7	8	9	10
	GND	GND	GND	GND	NC	GND	DATA(+)	GND	DATA(-)	PD Bias
Pin	20	19	18	17	16	15	14	13	12	11
	NC	NC	NC	NC	GND	GND	FLAG(-)	GND	FLAG(+)	V _{cc}

Safety

Please embrace all customary precautions & discretion while handling this device.

Optical	<ul style="list-style-type: none">• Avoid direct eye exposure to laser beam projection area or a broken fiber under operation.
Electrical	<ul style="list-style-type: none">• Warning against excessive overvoltages or current surges as these may cause failure or electrical shock.• Solder leads to electronics entirely so as to eschew short circuits.• Solder or plug in device while power is turned off.
Other	<ul style="list-style-type: none">• Avoid storage above maximum temperature rating & other extreme conditions.• Avoid device disassemblment as damages may be incurred.• Avoid excessive force to fiber pigtail and bending beyond a 30 mm radius.• Take normal handling precautions as for all electrostatic sensitive devices.

Appendix

Terms

BER: Bit Error Rate

SD: indicates the presence of an incoming signal level that has a workable BER

GND: Ground

NC: not connected

Additional Information

Contact

For additional information, product specifications, or information about Optocom:

Internet: <http://www.optocom.com>

Email: Info@optocom.com

Tel: +1 978 988 8711

Fax: +1 978 988 8722